

9D BLOCK 110V REV. 1. BULB/CAPILLARY

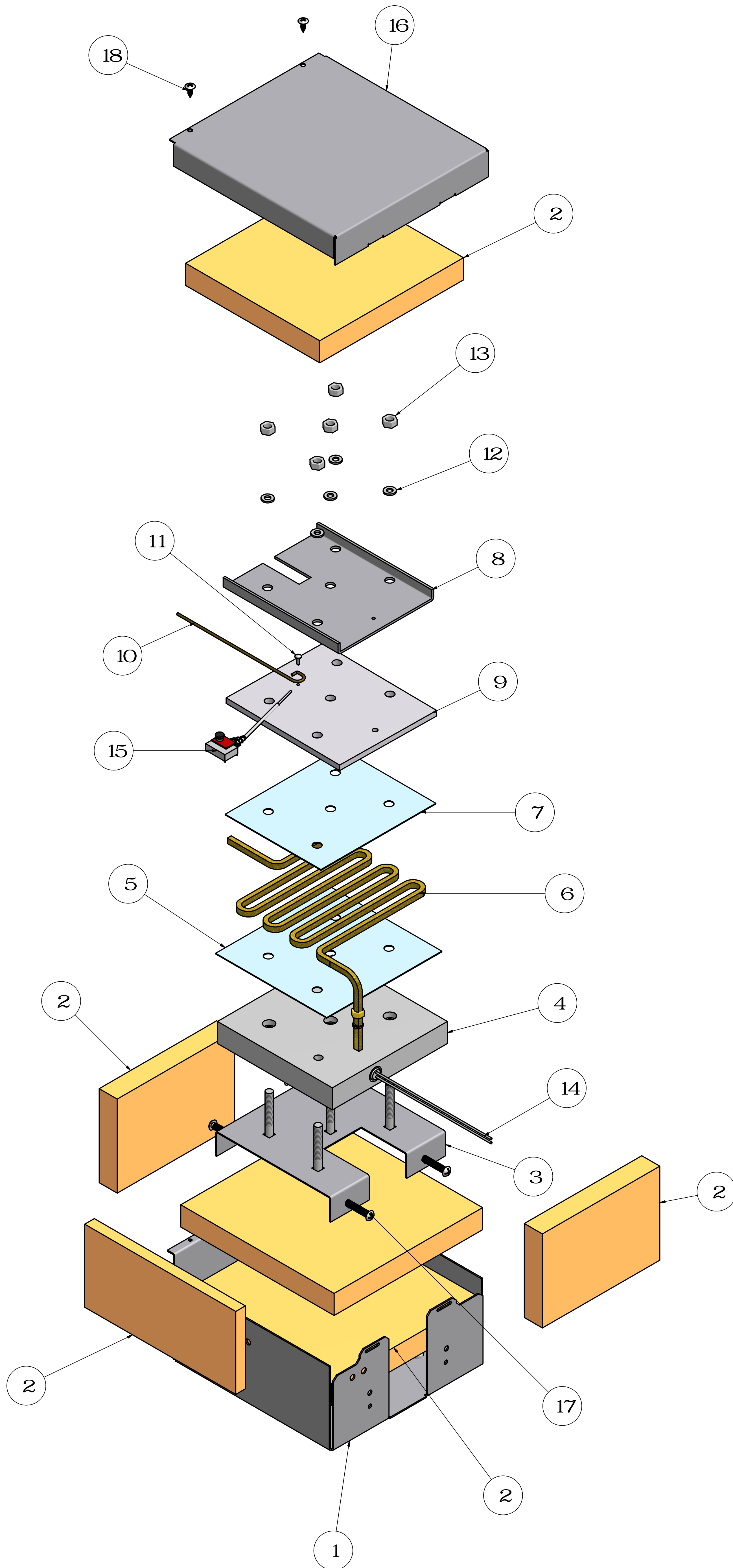

9D RAPID CHANGE KIT

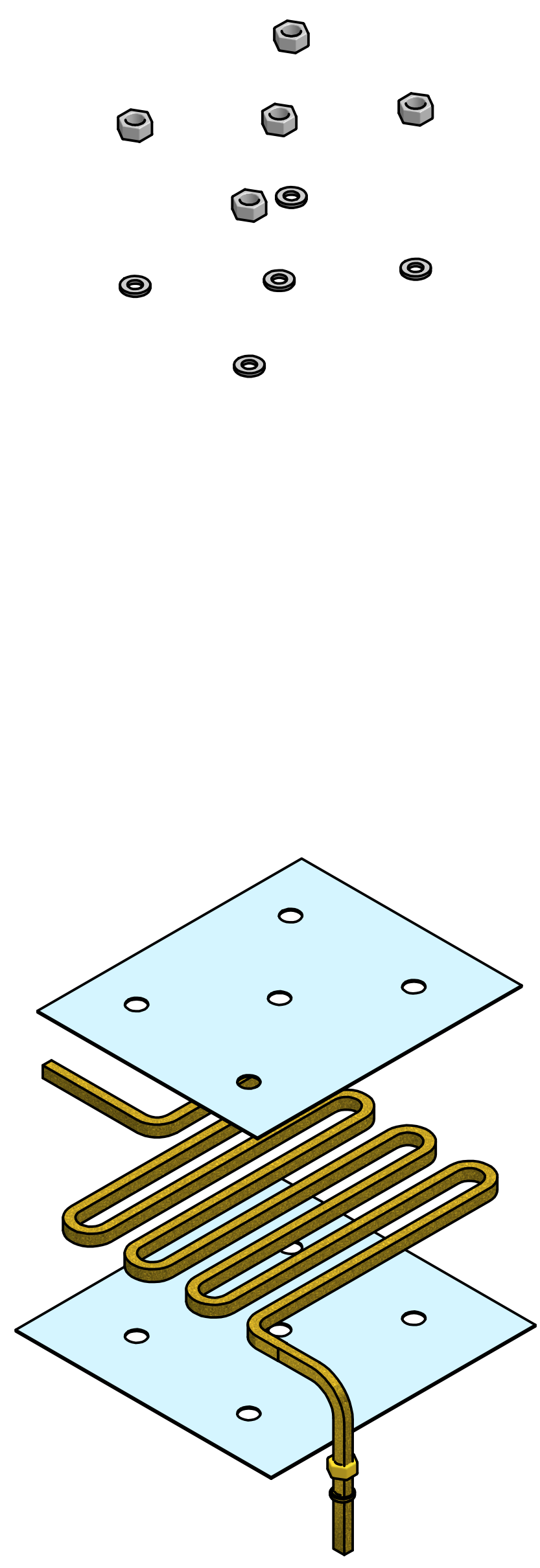

PARTS LIST

ITEM	QTY	SALES NUMBER	DESCRIPTION
1	1	CXP 1256	RAPID BLOCK HOLDER BASE
2	2	CXP 2483	STAGE/SHOW/FFI/9D INSULATION KIT
3	1	CXP 1255	RAPID BLOCK BASE PLATE (BOLT)
4	1	CXP 4067	STAGE/FPI/9D 1" ALUMINUM CARTRIDGE PLATE
5	1	CXP 1214	9D RAPID CHANGE KIT
6	1	CXP 1214	9D RAPID CHANGE KIT
7	1	CXP 1214	9D RAPID CHANGE KIT
8	1	CXP 4239	ANTI WARP PLATE RAPID BLOCK
9	1	CXP 4231	QUICK CHANGE ALUMINUM 1/4" TOP PLATE
10	1	CXP 4005	NEW THERMOCOUPLE ASSEMBLY
11	1		6/32" X 1/4" PHILIPS SCREW S.S.
12	5	CXP 1214	9D RAPID CHANGE KIT
13	5	CXP 1214	9D RAPID CHANGE KIT
14	1	CXP 4066	STAGE/FPI/9D 110V 1400W HEATER CARTRIDGE
15	1	CXP 7500	CAPILLARY THERMOSTAT ASSEMBLY
16	1	CXP 1258	RAPID BLOCK HOLDER LID
17	4	CXP 1257	# 12 X 2" PAN PHILLIPS SCREW
18	2		#8 X 1/2" PHILLIPS SELF TAPPER SCREW

9D BLOCK 110V REV.1. BULB/ CAPILLARY

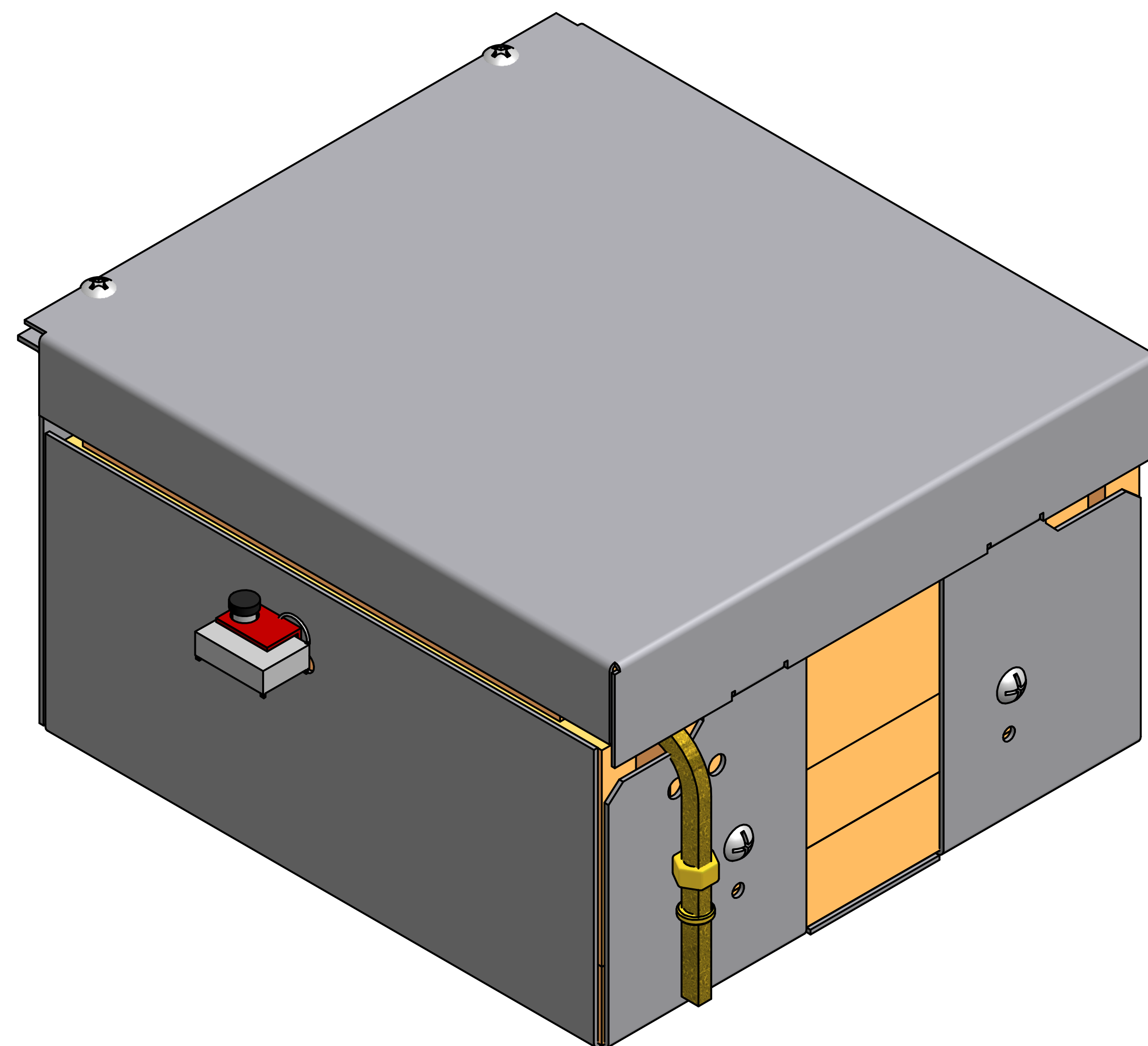

REVISION HISTORY	
REV-#	DATE
A	2009/2016